

- A WATER FILLER CAP, FRESH WATER
- B OIL FILLER CAP, ENGINE
- C OIL DIPSTICK, ENGINE LEFT OR RIGHT SIDE MOUNTED
- D ENGINE CONTROL UNIT
- E OIL DRAIN (WITH PUMP), ENGINE Ø25
- F OIL FILTER MAIN
- G OIL FILTER BYPASS
- H LIFTING EYE
- I WATER DRAIN, FRESH WATER
- J WATER DRAIN, SEA WATER
- K AIR FILTER
- L FUEL FILTER
- M HOT WATER OUTLET
- N HOT WATER INLET
- P SEA WATER INLET Ø38
- Q OIL DIPSTICK REVERSE GEAR
- R CENTRE OF GRAVITY
- T OIL FILTER AND OIL SUCTION REVERSE GEAR
- U FUEL INLET CONNECTION
- V FUEL RETURN TO TANK
- X ENGINE STOP
- Y CRANKCASE VENTILATION
- Z EXHAUST RISER Ø 102 (4") (Ø100)
- MA SEA WATER PUMP
- AB EXHAUST ELBOW Ø102 (4")
- AC EXTRA ALTERNATOR
- AD DIAGNOSE CONNECTOR
- AE ELASTIC SUSPENSION (4x)

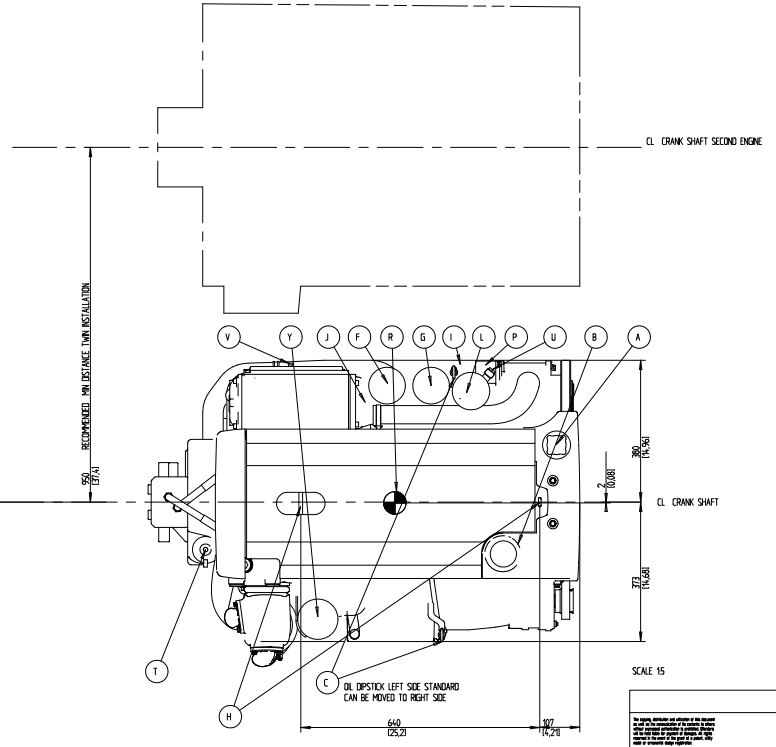
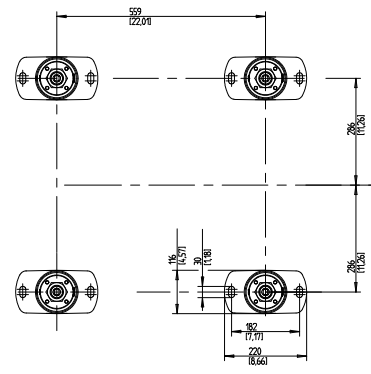

SCALE 1:5

<p>SYMBOLS, DIMENSIONS AND OTHER INFORMATION ARE GIVEN IN THIS DRAWING UNLESS OTHERWISE SPECIFIED.</p>	
<p>ENGINE DIMENSIONS DA H563VE</p>	
<p>DISPOSITION DRAWING</p>	
<p>3591860</p>	
<p>Scale</p>	<p>Sheet no.</p>
<p>1:5</p>	<p>102</p>