

Life- and Rescue Boat Propulsion Engines

D4/D6 SOLAS

132–320 kW (180–435 hp) crankshaft power acc. to ISO 8665

New powerful D4/D6 SOLAS range

Volvo Penta has now introduced a new powerful SOLAS approved range for use in fast rescue boats, lifeboats and tender boats: the D4-180, D4-225, D4-260, D6-300, D6-330, D6-370 and D6-400, D6-435, D6-435 WJ common rail marine diesel engines with rating 4 and 5 power settings. The engines are SOLAS approved for both inboard, waterjet and sterndrive propulsion.



Designed to withstand the tough Life- and Rescue boat environment

The D4/D6 Life- and Rescue boat engines are designed to comply with the requirements in the following regulations and standards:

- Council Directive 96/98/EC, as amended by Commission Directive 2002/75/EC
- SOLAS 74 Convention, as amended, Reg. III/4 and Reg. III/34
- LSA Code
- IMO Resolution MSC. 48(66)
- IMO Res. MSC. 81(70), Part 1, paras. 6.10.2 to 6.10.6 and 6.14.6 to 6.14.8.
- U.S.C.G.

SOLAS specifications

The SOLAS regulations specify the following demands for the engine:

- Withstand free fall of the lifeboat from 3 meters
- Withstand a lateral impact of 3.5 m/s of the lifeboat
- Stop automatically on capsizing and easily restart
- Fuel and lubricating systems shall prevent the loss of fuel and oil during capsizing
- Work submerged in water to the crankshaft centerline
- Work for not less than 5 min. after starting cold with the lifeboat out of the water

- Run properly at an angle of up to 10° trim and an angle of up to 20° list, either way
- Manual starting system or power starting system with two independent sources
- The lifeboat engine shall be designed to limit electromagnetic emissions
- The engine to be started without heater down to -15°C (-30°C with heater)
- For gear & sterndrives, see note

Standard high performance engines

All SOLAS engines are based on standard engine designs with SOLAS kits mounted and are tested in factory before delivery to boat builders. The major changes are a new position of the existing alternator and a new crankcase ventilation shutoff valve.

The design will extend the engine by approx. 270 mm in fore end to accommodate the new position of the alternator. The void space can be used to accommodate the batteries, as usual. See the drawing on page 2 for more information regarding dimensions of the SOLAS kit for D4/D6.

The SOLAS kit also includes a tilt switch, to be mounted on the engine bulkhead.

The base engine mounts are originally designed for high G-forces. Thus, there is no need for extra reinforcement for fast rescue boats and lifeboat applications to meet the SOLAS demands.

EVC for full control in all situations

All engines are equipped with EVC, the latest development in engine control and instrumentation for Volvo Penta marine engines, for easy installation and easy handling. For self righting boats, see note.

A propulsion package fully matched, tested and supported by one company

The engines and the drives are developed and produced by Volvo Penta, and the service of the engines will be well taken care of by more than 5,000 Volvo Penta commercial and leisure dealers around the world.

Meeting new emission standards

The common rail injection system in combination with electronics and an advanced combustion system are setting new standards in minimizing noxious emissions and particulates. The engines comply with IMO NOx limits and the comprehensive emission requirements EU RCD and US EPA Tier 3 rating 5 Marine Leisure, rating 4 Marine Commercial).

Certificate

The engines will be delivered with a certificate and marked with a wheelmark in accordance with the MED/SOLAS regulations. For the installation, see note.

**VOLVO
PENTA**

D4/D6 SOLAS

Technical description

For full technical information and performance data for the D4 and D6 engines, please see the product bulletins and technical data sheets for the selected power setting and model of D4 and D6 engine family.

Technical Data

Crankshaft power + dry weight BT inboard

D4-180:

@ 2800 rpm, kW (hp) 132 (180)

kg (lb) 482 (1063)

D4-225:

@ 3500, kW (hp) 165 (225)

kg (lb) 482 (1063)

D4-260:

@ 3500 rpm, kW (hp) 191 (260)

kg (lb) 482 (1063)

D6-300:

@ 3500 rpm, kW (hp) 221 (301)

kg (lb) 580 (1279)

D6-330:

@ 3500 rpm, kW (hp) 243 (330)

kg (lb) 580 (1279)

D6-370:

@ 3500 rpm, kW (hp) 272 (370)

kg (lb) 580 (1279)

D6-400:

@ 3500 rpm, kW (hp) 294 (400)

kg (lb) 594 (1310)

D6-435:

@ 3500 rpm, kW (hp) 320 (435)

kg (lb) 594 (1310)

D6-435 WJ:

@ 3500 rpm, kW (hp) 320 (435)

kg (lb) 584 (1287)

Battery

Minimum requirements for cold start:

- 12V, 1150 CCA for D4 engines
- 12V, 2300 CCA for D6 engines

Cold starting device

2 kW engine coolant heater to be installed for coldstarts below -15°C (down to -30°C)

Reverse gear

- Reverse gear with matched drop center and 8° down angle for compact installation and minimum propeller shaft angle.
- Bevel gears which results in smooth running at all speeds
- Hydraulically operated clutch for smooth shifting
- Electrical shifting performed by electromagnetic valves
- Seawater-cooled oilcooler

Waterjet

- For selection of waterjet please contact your waterjet dealer.

Sterndrive DPH

- Complete with transom shield, and installation components
- Max tilt angle 50° (adjustable)
- Protective zinc anodes to prevent corrosion
- Built-in kick-up function to reduce possible damage, in the event the drive strikes an underwater object
- Electrical shifting performed by electronic actuator
- Power Trim with one-button operation in twin installation

- Fully integrated water inlet and exhaust system
- Fully hydraulic power-assisted steering system
- Isolated propellers to prevent corrosion

NOTE

The SOLAS kit only covers certification of the engine, not the installation. For self righting boats following needs must be arranged by the yard:

- Sea water safe controls and display
- Exhaust system designed to avoid water ingress when capsizing
- Propeller protection
- Heating of sterndrive and gear in cold temperatures below -15°C

Contact your local Volvo Penta dealer for further information. Not all models, standard equipment and accessories are available in all countries. All specifications are subject to change without notice. The engine illustrated may not be entirely identical to production standard engines.

Dimensions

Dimensions shown are additional dimensions for SOLAS kit on D4 and D6. Not for installation. For more dimensions, please refer to the respective product bulletin and installation drawing.

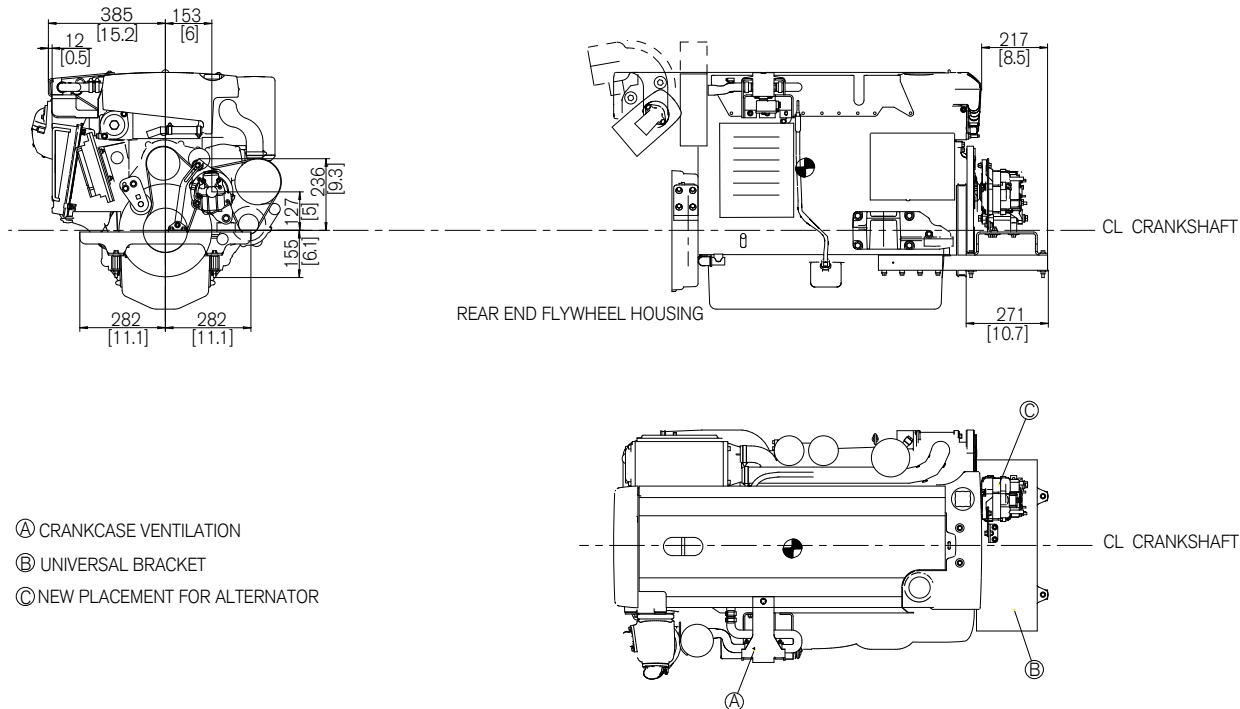

- Ⓐ CRANKCASE VENTILATION
- Ⓑ UNIVERSAL BRACKET
- Ⓒ NEW PLACEMENT FOR ALTERNATOR

VOLVO PENTA

AB Volvo Penta
SE-405 08 Göteborg, Sweden
www.volvopenta.com