

# VOLVO PENTA AQUAMATIC DUOPROP

# D3-140, 170, 200, 220/DPS

103-125-147-162 kW (140-170-200-220 hp) crankshaft power acc. to ISO 8665



Available  
with Joystick!

## The new D3

Volvo Penta's new D3 has been developed using the latest available engine technology. It only has the name and number of cylinders in common with the first generation D3.

- Common rail system with piezo-electric injectors
- Equipped with Volvo Penta EVC-D for electronic shift & throttle
- Lightweight and compact
- Quiet and comfortable



### World-class performance

The 1800 bar common rail fuel injection system with piezo-electric injectors performing multiple injections per cycle gives an extraordinary performance. In combination with a Variable Geometry Turbocharger (VGT) this ensures outstanding acceleration, with no sign of smoke.

### Robust, compact and lightweight

With cast-in grey iron cylinder liners, integrated freshwater pump, and a neatly designed marinization based on Volvo Penta's unique experience, the new D3 is a very robust engine. It is ultra-compact for its swept volume and fully symmetrical, making the package very easy to install.

Aluminum cylinder block and head gives the engine an extremely low weight for its power output.

The D3 is equipped with an engine cover that in addition to protecting the engine also gives it a modern and exclusive appearance.

### Comfort

The D3 is equipped with the same type of successful engine mounts that were introduced for the D4/D6 engines. The multiple injection system in combination with the new type of engine mounts makes the engine amazingly quiet and comfortable at low speeds.

### EVC-D

EVC-D, a new generation of the proven Electronic Vessel Control offers the best driver experience available!

The new ergonomically designed controls engage smoothly and allow for maneuvering with fingertip precision in any situation. Integrated pushbuttons give easy access to functions such as Power Trim Assistant, Tow Mode and Single Lever Control, which allows for safe and easy boating.

Complete the helm with your choice from the full range of easy to read gauges and displays including the new 7" color display. Add the trip computer function for accurate fuel management and minimized environmental impact. Engine synchronisation is of course standard in twin installations.

### DPS drive

The Duoprop drive with its twin counter-rotating propellers is the optimum propulsion system for planing boats. The DPS drive features exhaust outlets through the propeller hub and cavitation plate producing a harmonious drive unit with unbeatable characteristics in the boat in terms of speed, acceleration, steering, maneuvering, noise and vibration.

The boat can be equipped with PTA, Power Trim Assistant, an EVC accessory that automatically trims the drive during the acceleration phase and at normal cruising speed, giving optimized performance.

### Meeting new emission standards

The engine has outstandingly low emissions. It complies with the requirements of the world's most stringent emission regulation, US EPA Tier 3, that will be in force year 2012.

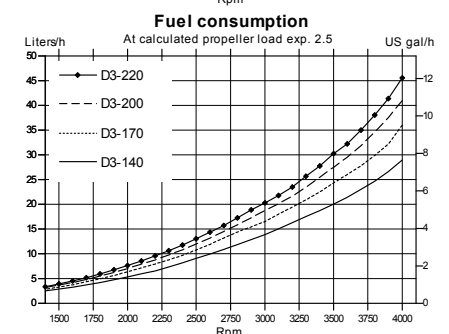
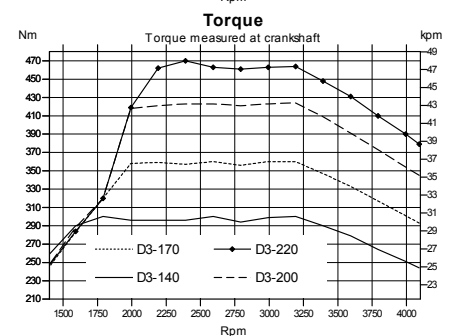
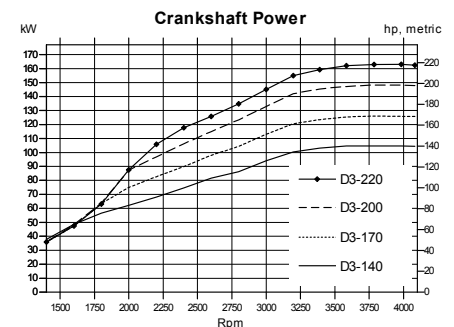

**VOLVO  
PENTA**

# D3-140,170,200,220/DPS

## Technical description:

### Engine block and head

- Cylinder block and head made of aluminum
- Cylinder block with integrated bed plate
- 4-valve technology with hydraulic lash adjusters
- Double overhead camshafts
- Oil-cooled pistons with two compression rings and one oil scraper ring
- Cast-in grey iron cylinder liners
- Replaceable valve seats
- Six-bearing crankshaft
- Front-end transmission

### Engine mounting

- Flexible engine mounting

### Lubrication system

- Easily replaceable (insert) full-flow oil filter
- Plate oil cooler

### Fuel system

- Common rail fuel injection system
- Piezo-electric injectors
- Constant power output regardless of fuel quality or temperature (5–55°C/41–131°F)
- Fine filter with water separator and water in fuel sensor with alarm

### Air inlet and exhaust system

- Replaceable air filter

- Closed crankcase ventilation with oil separator and filter
- Stainless steel exhaust elbow
- Turbocharger with variable geometry

### Cooling system

- Thermostatically regulated freshwater cooling
- Tubular heat exchanger with separate large volume expansion tank
- Coolant system prepared for hot water outlet
- Easily accessible impeller pump
- Integrated seawater coolant pick-up through drive
- Seawater strainer

### Electrical system

- 12V one-pole electrical system
- 150A alternator, and integrated temperature compensated charging regulator
- Auxiliary stop button

### Instruments/control

- Electronic shift and throttle
- Full range of instrumentation available

### Drive

- Cone clutch
- Pattern-matched spiral bevel gears
- Complete connection for exhaust outlet through the propeller hub and cavitation plate
- Overload protection sleeve (break-away coupling)
- Max tilt angle 52°

- The drive can be turned 28° in each direction
- Built-in kick-up function to reduce possible damage, in the event the drive strikes an underwater object
- Active corrosion protection as accessory
- Integrated speedometer (pitot tube) pickup in lower drive leg
- Easy to access drive anode placed on the back of the cavitation plate
- Optional electronic steering – prerequisite for Sterndrive Joystick. Twin installation only. This option is not retrofittable.

### Power Trim

- Shield integrated high capacity trim pump for quick trim response and easy installation
- Digital Power Trim instrument with analog or digital reading

### Accessories

An extensive range of accessories are available. For detailed information, please see the Accessories & Maintenance Parts catalog ([www.volvopenta.com](http://www.volvopenta.com)).

Contact your local Volvo Penta dealer for further information.

Not all models, standard equipment and accessories are available in all countries. All specifications are subject to change without notice.

The engine illustrated may not be entirely identical to production standard engines.

## Technical Data

Engine designation	<b>D3-140 A</b>	<b>D3-170 A</b>	<b>D3-200 A</b>	<b>D3-220 A</b>
Crankshaft power, kW (hp)	103 (140)	125 (170)	147 (200)	162 (220)
Propeller shaft power, kW (hp)	98 (133)	119 (162)	140 (190)	154 (209)
Engine speed, rpm	4000	4000	4000	4000
Displacement, l (in <sup>3</sup> )	2.4 (146)	2.4 (146)	2.4 (146)	2.4 (146)
Number of cylinders	5	5	5	5
Bore/stroke, mm (in.)	81/93.2 (3.19/3.67)	81/93.2 (3.19/3.67)	81/93.2 (3.19/3.67)	81/93.2 (3.19/3.67)
Compression ratio	16.5:1	16.5:1	16.5:1	16.5:1
Volvo Penta Duoprop drive	<b>DPS</b>	<b>DPS</b>	<b>DPS</b>	<b>DPS</b>
Ratio	2.14:1	2.14:1	1.95:1	1.78:1
Dry weight with DPS, excl. prop., kg (lb)	363 (800)	363 (800)	363 (800)	363 (800)

Duty rating: R5

Technical data according to ISO 8665. With fuel having an LHV of 42,700 kJ/kg and density of 840 g/liter at 15°C (60°F).

Merchant fuel may differ from this specification which will influence fuel consumption.

The engine complies with IMO NOx (D3-200 & D3-220) and the comprehensive emission requirements EU RCD and US EPA Tier 2.

Prepared to meet the upcoming US EPA Tier 3 regulations.

## Dimensions D3-140,170,200,220/DPS

Not for installation

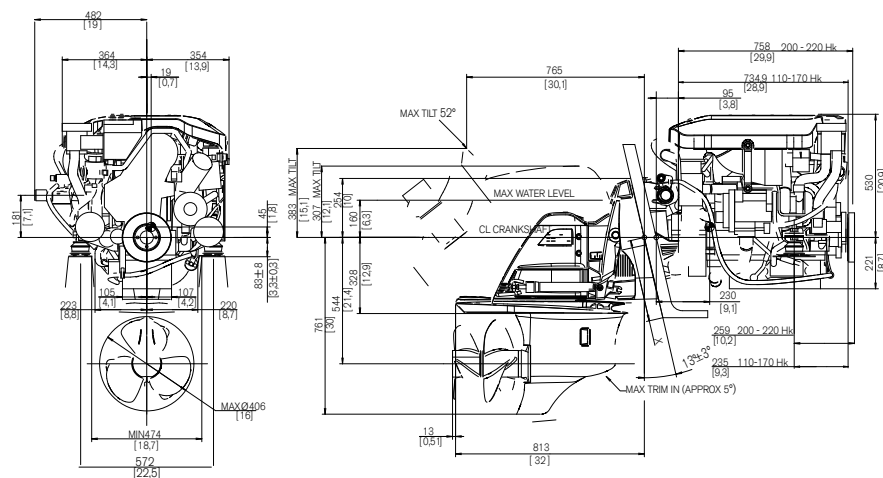

### The Joystick Revolution (option)

Crowded marina. Strong side wind. Tight berth. Situations that can make even the most seasoned skipper a little edgy. Not anymore. Volvo Penta Sterndrive Joystick puts you in total control and lets you maneuver in any direction – sideways, diagonally, forward, backward or rotate – with just one hand.

Visit [volvopenta.com](http://volvopenta.com) to see for yourself!

# VOLVO PENTA

AB Volvo Penta

SE-405 08 Göteborg, Sweden  
[www.volvopenta.com](http://www.volvopenta.com)